

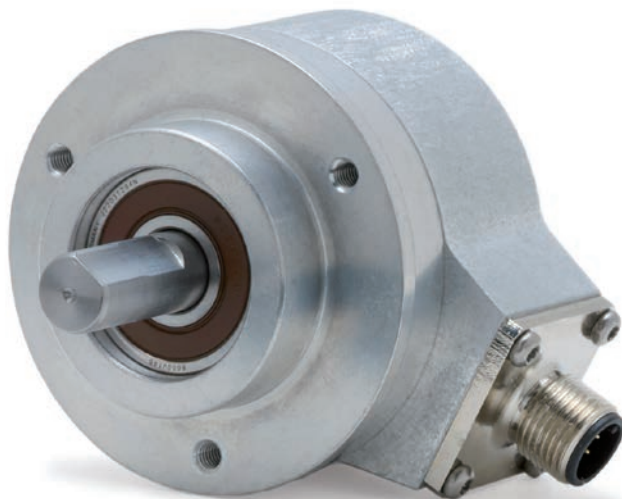

HEIDENHAIN



**Functional
Safety**

Product Information

ROC 425

ROQ 437

Absolute Rotary Encoders
with EnDat 2.2 for
Safety-Related Applications

ID 1322270-xx

ID 1322271-xx

ID 1322275-xx

ID 1322276-xx

03/2021

ROC 425, ROQ 437 with synchro flange

Rotary encoders for absolute position values with safe singletum information

- Rotary encoders for separate shaft coupling
- 01C synchro flange
- 92A solid shaft with flat

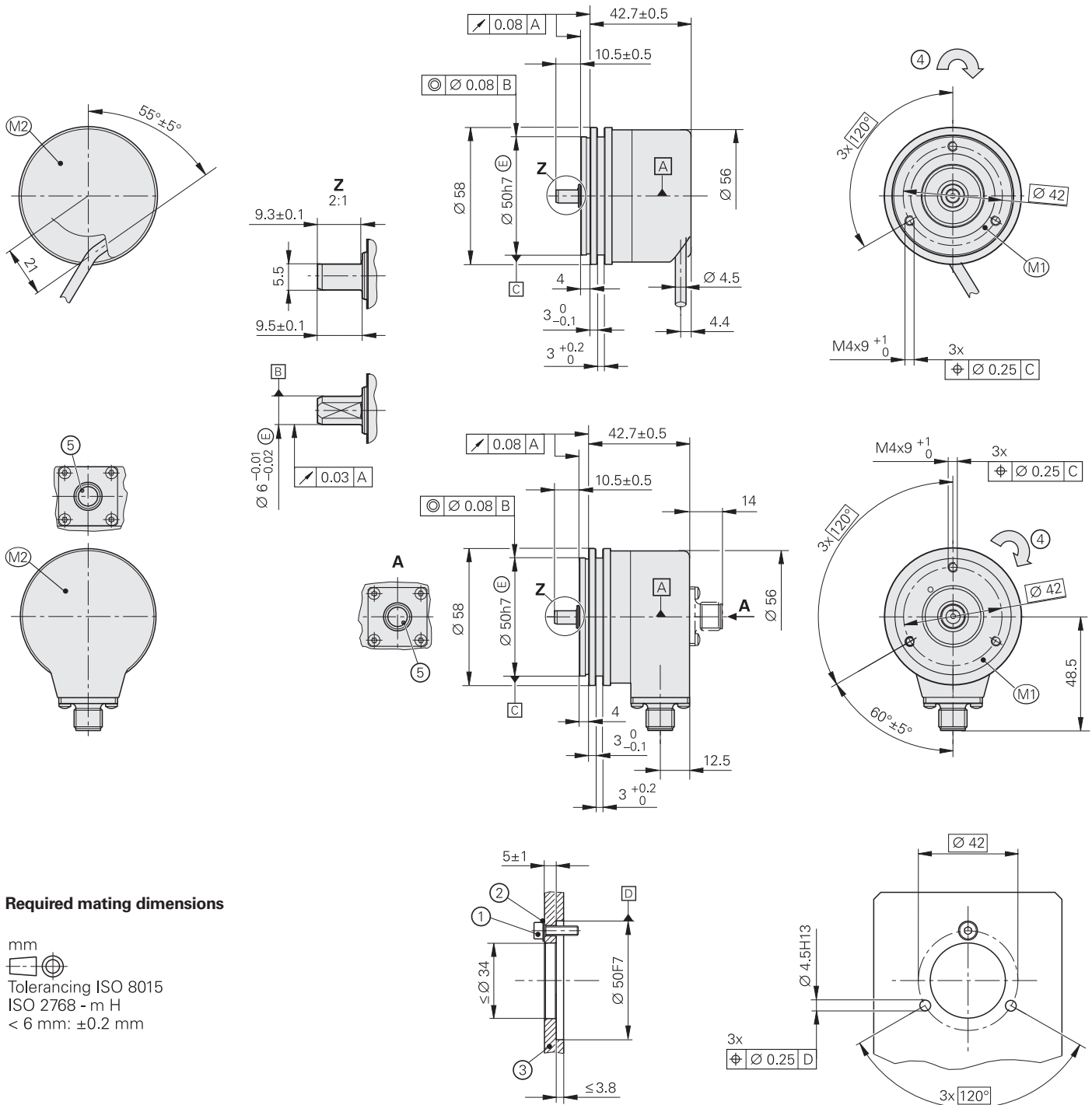

Required mating dimensions

mm
 Tolerancing ISO 8015
 ISO 2768 - m H
 < 6 mm: ± 0.2 mm

- ☒ = Encoder bearing
- M1 = Measuring point for operating temperature
- M2 = Measuring point for vibration; see also D 741714
- 1 = M4 - 8.8 screw with material bonding anti-rotation lock; tightening torque: $2.65 \text{ Nm} \pm 0.1 \text{ Nm}$; minimum engagement depth: 6 mm
- 2 = At a permissible interface pressure PG of $\leq 280 \text{ N/mm}^2$, use a washer
- 3 = For material characteristics, see the table on the "Mounting" page
- 4 = Direction of shaft rotation for ascending position values
- 5 = Connector coding

Specifications	ROC 425 – singleturm	ROQ 437 – multiturm
Functional safety for applications with up to	For monitoring and closed-loop functions in the singleturm range: <ul style="list-style-type: none"> • SIL 2 as per EN 61508 (further basis for testing: EN 61800-5-2) • Category 3, PL d as per EN ISO 13849-1:2015 	
PFH ¹⁾	$\leq 10 \cdot 10^{-9}$ (probability of dangerous failure per hour)	
Safe position ²⁾	<i>Encoder</i> : $\pm 1.76^\circ$ (safety-related measuring step: SM = 0.7°); <i>mechanical coupling</i> : $\pm 0^\circ$ (fault exclusion for stator coupling and shaft breakage, designed for accelerations $\leq 300 \text{ m/s}^2$)	
Interface	EnDat 2.2	
Ordering designation	EnDat22	
Position values per revolution	33554432 (25 bits)	
Revolutions	–	4096 (12 bits)
Calc. time t_{cal} / clock freq.	$\leq 7 \mu\text{s} / \leq 16 \text{ MHz}$	
System accuracy	$\pm 20''$	
Electrical connection**	8-pin M12 radial* or axial flange socket (male), or 1 m PUR cable with 8-pin M12 coupling (male)	
Cable length ³⁾	$\leq 100 \text{ m}$ (at clock frequency $\leq 8 \text{ MHz}$) $\leq 20 \text{ m}$ (at clock frequency $\leq 16 \text{ MHz}$)	
Supply voltage	DC 3.6 V to 14 V	
Power consumption ⁴⁾ (maximum)	At 3.6 V: $\leq 600 \text{ mW}$; at 14 V: $\leq 700 \text{ mW}$	At 3.6 V: $\leq 700 \text{ mW}$; at 14 V: $\leq 800 \text{ mW}$
Current consumption (typical)	5 V: 80 mA (without load)	5 V: 95 mA (without load)
Shaft	92A solid shaft $\varnothing 6 \text{ mm}$ with flat	
Speed	$\leq 15000 \text{ rpm}$	$\leq 12000 \text{ rpm}$
Starting torque (typical)	0.01 Nm (at 20 °C)	
Moment of inertia of rotor	$2.9 \cdot 10^{-6} \text{ kgm}^2$	
Angular acceleration of rotor	$\leq 1 \cdot 10^5 \text{ rad/s}^2$	
Shaft load	<i>Axial</i> : $\leq 40 \text{ N}$; <i>radial</i> : $\leq 60 \text{ N}$ at shaft end	
Vibration 55 Hz to 2000 Hz Shock 6 ms	$\leq 300 \text{ m/s}^2$ (EN 60068-2-6); 10 Hz to 55 Hz constant over 4.9 mm peak to peak $\leq 2000 \text{ m/s}^2$ (EN 60068-2-27)	
Min. operating temp.	<i>Flange socket or fixed cable</i> : $-40 \text{ }^\circ\text{C}$; <i>moving cable</i> : $-10 \text{ }^\circ\text{C}$	
Max. operating temp. ⁵⁾	100 °C	
Trigger threshold ⁶⁾ of temperature exceedance error message	125 °C in the scanning ASIC (measuring accuracy of the internal temperature sensor: $\pm 1 \text{ K}$)	
Relative humidity	$\leq 93 \%$ (40 °C/21 d as per EN 60068-2-78); without condensation	
Protection EN 60529	Housing: IP67; shaft inlet: IP64 (read about insulation under <i>Electrical safety</i> in the <i>Interfaces of HEIDENHAIN Encoders</i> brochure; contamination from the ingress of fluids must be avoided)	
Mass	$\approx 0.3 \text{ kg}$	
ID number	1322270-01* / 1322270-02	1322275-01* / 1322275-02

* This preferred version is available on short notice

** Please select when ordering

¹⁾ For use at $\leq 2000 \text{ m}$ above sea level ($\leq 6000 \text{ m}$ above sea level upon request)

²⁾ Further tolerances may arise in subsequent electronics after position value comparison (contact mfr. of subsequent electronics)

³⁾ See the EnDat description in the *Interfaces of HEIDENHAIN Encoders* brochure

⁴⁾ See *General electrical information* in the *Interfaces of HEIDENHAIN Encoders* brochure

⁵⁾ For the relationship between operating temperature / shaft speed / supply voltage, see *General mechanical information* in the *Rotary Encoders* brochure

⁶⁾ The internal temperature evaluation is not designed for functional safety

ROC 425, ROQ 437 with clamping flange

Rotary encoders for absolute position values with safe singletum information

- Rotary encoders for separate shaft coupling
- 03C clamping flange
- 03D solid shaft with flat

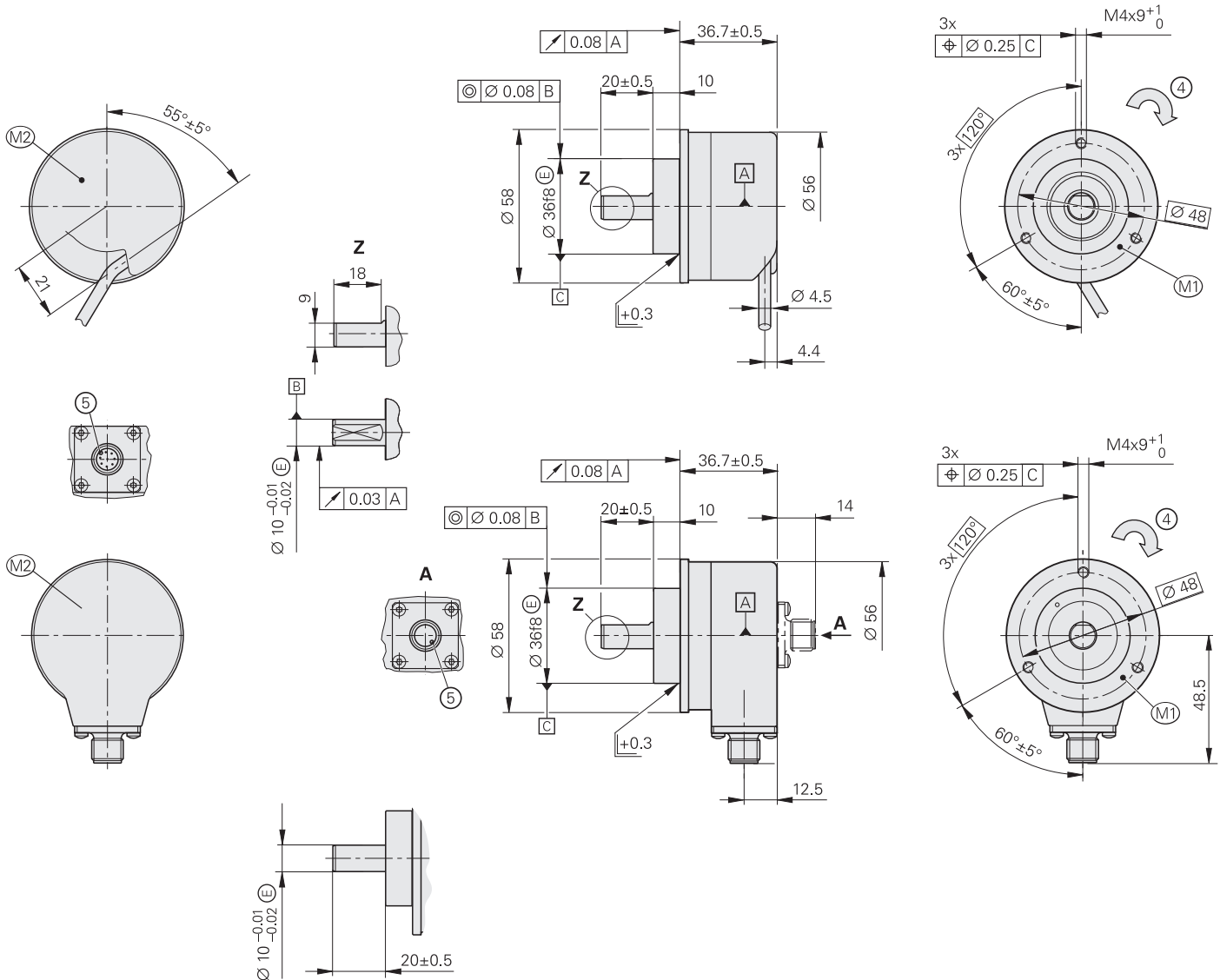

Required mating dimensions

mm

 Tolerancing ISO 8015
 ISO 2768 - m H
 <math>< 6\text{ mm}</math>: $\pm 0.2\text{ mm}$

- ☒ = Encoder bearing
- M1 = Measuring point for operating temperature
- M2 = Measuring point for vibration; see also D 741714
- 1 = M4 – 8.8 screw with material bonding anti-rotation lock; tightening torque: $2.65\text{ Nm} \pm 0.1\text{ Nm}$; minimum engagement depth: 6 mm
- 2 = At a permissible interface pressure PG of $\leq 280\text{ N/mm}^2$, use a washer
- 3 = For material characteristics, see the table on the "Mounting" page
- 4 = Direction of shaft rotation for output signals in accordance with the interface description
- 5 = Connector coding

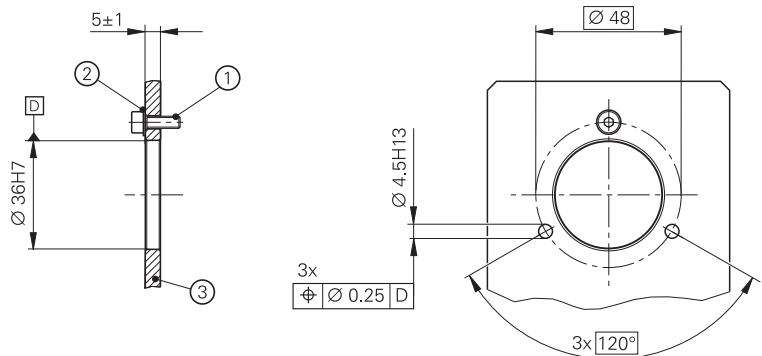

Specifications	ROC 425 – singleturn	ROQ 437 – multiturn
Functional safety for applications with up to	For monitoring and closed-loop functions in the singleturn range: <ul style="list-style-type: none"> • SIL 2 as per EN 61508 (further basis for testing: EN 61800-5-2) • Category 3, PL d as per EN ISO 13849-1:2015 	
PFH ¹⁾	$\leq 10 \cdot 10^{-9}$ (probability of dangerous failure per hour)	
Safe position ²⁾	<i>Encoder</i> : $\pm 1.76^\circ$ (safety-related measuring step: SM = 0.7°); <i>mechanical coupling</i> : $\pm 0^\circ$ (fault exclusion for stator coupling and shaft breakage, designed for accelerations $\leq 300 \text{ m/s}^2$)	
Interface	EnDat 2.2	
Ordering designation	EnDat22	
Position values per revolution	33554432 (25 bits)	
Revolutions	–	4096 (12 bits)
Calc. time t_{cal} / clock freq.	$\leq 7 \mu\text{s} / \leq 16 \text{ MHz}$	
System accuracy	$\pm 20''$	
Electrical connection**	8-pin M12 radial* or axial flange socket (male), or 1 m PUR cable with 8-pin M12 coupling (male)	
Cable length ³⁾	$\leq 100 \text{ m}$ (at clock frequency $\leq 8 \text{ MHz}$) $\leq 20 \text{ m}$ (at clock frequency $\leq 16 \text{ MHz}$)	
Supply voltage	DC 3.6 V to 14 V	
Power consumption ⁴⁾ (maximum)	At 3.6 V: $\leq 600 \text{ mW}$; at 14 V: $\leq 700 \text{ mW}$	At 3.6 V: $\leq 700 \text{ mW}$; at 14 V: $\leq 800 \text{ mW}$
Current consumption (typical)	5 V: 80 mA (without load)	5 V: 95 mA (without load)
Shaft	Ø3D solid shaft $\varnothing 10 \text{ mm}$ with flat	
Shaft speed	$\leq 15000 \text{ rpm}$	$\leq 12000 \text{ rpm}$
Starting torque (typical)	0.01 Nm (at 20 °C)	
Moment of inertia of rotor	$2.9 \cdot 10^{-6} \text{ kgm}^2$	
Angular acceleration of rotor	$\leq 1 \cdot 10^5 \text{ rad/s}^2$	
Shaft load	<i>Axial</i> : $\leq 40 \text{ N}$; <i>radial</i> : $\leq 60 \text{ N}$ at shaft end	
Vibration 55 Hz to 2000 Hz Shock 6 ms	$\leq 300 \text{ m/s}^2$ (EN 60068-2-6); 10 Hz to 55 Hz constant over 4.9 mm peak to peak $\leq 2000 \text{ m/s}^2$ (EN 60068-2-27)	
Min. operating temp.	<i>Flange socket or fixed cable</i> : $-40 \text{ }^\circ\text{C}$; <i>moving cable</i> : $-10 \text{ }^\circ\text{C}$	
Max. operating temp. ⁵⁾	100 °C	
Trigger threshold ⁶⁾ of temperature exceedance error message	125 °C in the scanning ASIC (measuring accuracy of the internal temperature sensor: $\pm 1 \text{ K}$)	
Relative humidity	$\leq 93 \%$ (40 °C/21 d as per EN 60068-2-78); without condensation	
Protection EN 60529	Housing: IP67; shaft inlet: IP64 (read about insulation under <i>Electrical safety</i> in the <i>Interfaces of HEIDENHAIN Encoders</i> brochure; contamination from the ingress of fluids must be avoided)	
Mass	$\approx 0.3 \text{ kg}$	
ID number	1322271-01* / 1322271-02 / 1322271-03	1322276-01* / 1322276-02

* This preferred version is available on short notice

** Please select when ordering

¹⁾ For use at $\leq 2000 \text{ m}$ above sea level ($\leq 6000 \text{ m}$ above sea level upon request)

²⁾ Further tolerances may arise in subsequent electronics after position value comparison (contact mfr. of subsequent electronics)

³⁾ See the EnDat description in the *Interfaces of HEIDENHAIN Encoders* brochure

⁴⁾ See *General electrical information* in the *Interfaces of HEIDENHAIN Encoders* brochure

⁵⁾ For the relationship between operating temperature / shaft speed / supply voltage, see *General mechanical information* in the *Rotary Encoders* brochure

⁶⁾ The internal temperature evaluation is not designed for functional safety

Mounting

The rotary encoders are centered by means of the centering collar of the synchro flange or clamping flange and are secured with screws at their front. Mechanical fault exclusion can be ensured only when mounting with three M4 screws of strength class 8.8 and at a minimum engagement depth of 6 mm in the rotary encoder flange. Screws are not included in delivery. The machine designer is responsible for specifying a material bonding anti-rotation lock for the screws depending on the application.

Fault exclusion was calculated based on a material bonding anti-rotation lock with a thread friction coefficient of between 0.1 and 0.16. The holes for the screws must be designed in accordance with EN 20273 (medium). The washers are required for materials with permissible interface pressures of $\leq 280 \text{ N/mm}^2$.

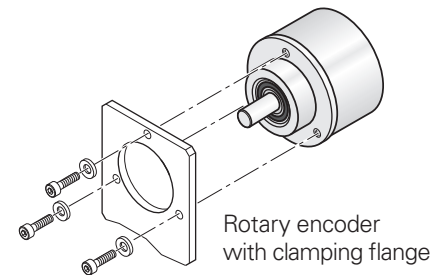
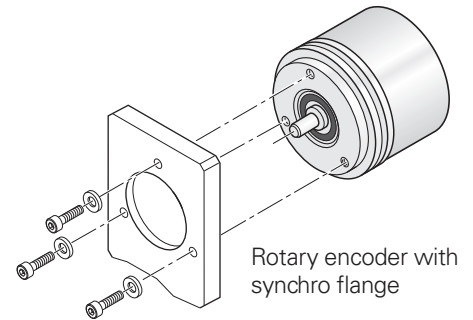

At variance with the standard specifications in the rotary encoders brochure, the following customer-side requirements are permissible for the safe mechanical coupling:

	Steel	Aluminum
Coefficient of thermal expansion α_{therm}	$10 \cdot 10^{-6} \text{ K}^{-1}$ to $14 \cdot 10^{-6} \text{ K}^{-1}$	$\leq 25 \cdot 10^{-6} \text{ K}^{-1}$
Thickness of the mounting flange	4 mm to 20 mm	5 mm \pm 1 mm

Rotary encoders may exert a torque of up to 1 Nm on the mating shaft. The customer-side mechanical design must be made for this load.

Cables with a length of more than 0.5 m must be provided with strain relief.



Further information:





For the customer-side mounting design, the materials specifications for steel apply to the customer-side shaft, and for the customer side stator, the materials specifications for aluminum.

Also pay attention to the other material properties in the *Encoders for Servo Drives* brochure (ID 208922-xx).

For mounting information and mounting aids, see the mounting instructions in the *Rotary Encoders* brochure.

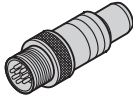
Electrical connection

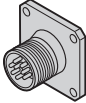
Pin layout

8-pin M12 coupling									
									
	Power supply				Serial data transmission				
	8	2	5	1	3	4	7	6	
	U_P	Sensor U_P	0V	Sensor 0V	DATA	$\overline{\text{DATA}}$	CLOCK	$\overline{\text{CLOCK}}$	
	Brown/Green	Blue	White/Green	White	Gray	Pink	Violet	Yellow	





Cable shield connected to housing; U_P = Power supply voltage

Sensor: The sense line is connected in the encoder with the corresponding power line.

Vacant pins or wires must not be used!

Note for safety-related applications: Only completely assembled HEIDENHAIN cables are qualified.
Do not modify cables or exchange their connectors without first consulting with HEIDENHAIN Traunreut.

Cables

PUR connecting and adapter cables \varnothing 6 mm; $(4 \times 0.14 \text{ mm}^2) + (4 \times 0.34 \text{ mm}^2)$; $A_P = 0.34 \text{ mm}^2$		
M12 connector (female) and 8-pin M12 coupling (male)		ID 368330-xx
8-pin M12 connector (female) and 15-pin D-sub connector (female)		ID 533627-xx
8-pin M12 connector (female) and 15-pin D-sub connector (male)		ID 524599-xx
8-pin M12 connector (female) and free cable end		ID 634265-xx ¹⁾

A_P : Cross section of power supply lines

¹⁾ Pay attention to the EMC requirements described under General electrical information in the *Interfaces of HEIDENHAIN Encoders* brochure

Note for safety-related applications: Document the bit error rate in accordance with Specification 533095!

HEIDENHAIN

DR. JOHANNES HEIDENHAIN GmbH

Dr.-Johannes-Heidenhain-Straße 5

83301 Traunreut, Germany

☎ +49 8669 31-0

FAX +49 8669 32-5061

E-mail: info@heidenhain.de

www.heidenhain.de

This Product Information document supersedes all previous editions, which thereby become invalid. The basis for ordering from HEIDENHAIN is always the Product Information document edition valid when the order is placed.

Further information:

To ensure proper and intended use, comply with the specifications in the following documents:

- Brochure: *Rotary Encoders* 249529-xx
- Brochure: *Interfaces of HEIDENHAIN Encoders* 1078628-xx
- Brochure: *Cables and Connectors* 1206103-xx
- Mounting instructions: *ROC 425, ROQ 437 (synchro flange)* 1344876-xx
- Mounting instructions: *ROC 425, ROQ 437 (clamping flange)* 1344880-xx
- Technical Information document: *Safety-Related Position Measurement Systems* 596632-xx
- For implementation in a safe control or inverter: Specification document: 533095-xx